

JOURNAL OF THE AMERICAN CHEMICAL SOCIETY

Registered in U. S. Patent Office. © Copyright, 1966, by the American Chemical Society

VOLUME 88, NUMBER 23

DECEMBER 5, 1966

Physical and Inorganic Chemistry

Molecular Ions. VI. Electronic Absorption and Electron Paramagnetic Resonance Spectra of Molecular Ions of Conjugated Dienes and Allyl Radicals

Tadamasa Shida¹ and William H. Hamill

Contribution from the Department of Chemistry and the Radiation Laboratory,² University of Notre Dame, Notre Dame, Indiana 46556. Received August 3, 1966

Abstract: Positive and negative molecular ions of butadiene and several homologs were prepared at -196° in γ -irradiated *sec*-butyl chloride and methyltetrahydrofuran glasses, respectively. Positive and negative ions have similar absorption spectra, as alternant hydrocarbons should. Values of λ_{\max} for the lowest two absorption bands are in good agreement with theoretical prediction based on simple Hückel molecular orbital theory. Band maxima of anions are not sensitive to substituent alkyl groups, whereas those of cations are red-shifted as the number of substituent methyl groups increases. In alcoholic matrices butadiene anions form allylic radicals by the reaction $\text{CH}_2=\text{CHCH}=\text{CH}_2^- + \text{ROH} \rightarrow \text{CH}_2=\text{CH}\dot{\text{C}}\text{HCH}_3 + \text{RO}^-$, confirmed by epr.

Molecular ions have been prepared by various chemical reactions. Concentrated sulfuric acid and other oxidizing reagents produce aromatic hydrocarbon cations.³ Alkali metals produce anions of such substances as aromatic hydrocarbons, carbonyl compounds, nitro compounds, and nitriles.^{4,5} Electrolysis and photolysis are also used for the production of molecular ions.⁵ However, when the reactions are carried out at room temperature, the ions may react or decompose giving spurious absorption bands. In addition, ion pairing of some molecular anions with the alkali metal cation sometimes causes very large Coulombic spectral shifts.⁶

γ -Radiolysis of organic solids at -196° is a comparatively clean, effective method to obtain molecular

ions.⁷ Although the over-all effect of γ irradiation of organic compounds is quite complex, the optical spectra of irradiated solids at low temperatures are fairly well understood in terms of ionic processes.⁷ In such systems the only mobile species present during irradiation are the ejected electron, the counterpart positive charge (hole) which migrates rapidly between like molecules, and the hydrogen atom. Therefore, in a dilute solid solution the changes in the solute are brought about by these mobile species. Depending on the chemical nature of the solvent, either electrons or positive holes can be immobilized. Thus, in alkyl chlorides positive charge is available to the solute, but ejected electrons are scavenged by the solvent itself. The mechanism of solute cation formation in such matrices is summarized by the reactions

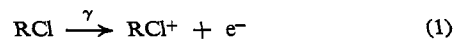

(1) On leave from the Institute of Physical and Chemical Research, Tokyo, Japan.

(2) The Radiation Laboratory of the University of Notre Dame is operated under contract with the U. S. Atomic Energy Commission. This is A.E.C. Document No. COO-38-499.

(3) (a) P. A. Malachuk, L. S. Marcoux, and R. N. Adams, *J. Phys. Chem.*, **70**, 2064 (1966); (b) W. F. Forbes and P. D. Sullivan, *J. Am. Chem. Soc.*, **88**, 2862 (1966).

(4) B. J. McClelland, *Chem. Rev.*, **64**, 301 (1964).

(5) E.g., P. H. Rieger and G. K. Fraenkel, *J. Chem. Phys.*, **39**, 609 (1963).

(6) B. J. McClelland, *Trans. Faraday Soc.*, **57**, 1458 (1961).

(7) (a) T. Shida and W. H. Hamill, *J. Chem. Phys.*, **44**, 2369 (1966); (b) *ibid.*, **44**, 2375 (1966); (c) *ibid.*, **44**, 4372 (1966); (d) *J. Am. Chem. Soc.*, **88**, 3683 (1966); (e) *ibid.*, **88**, 3689 (1966); (f) *ibid.*, **88**, 5376 (1966). In ref 7d, λ_{\max} values for acetone anion (466 m μ) and cation (740 m μ) were erroneously permuted in the abstract and also on p 3686 in line 23 of the first column and in lines 1 and 3 of the second column.

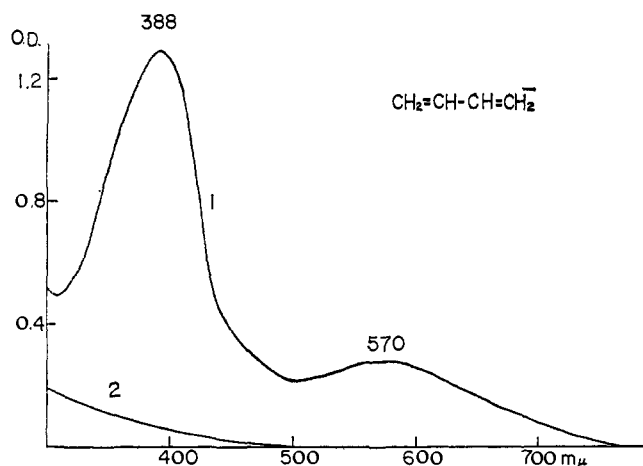
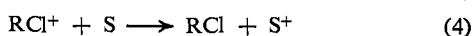
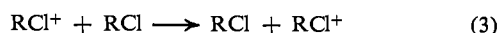
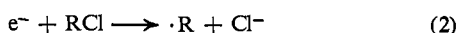
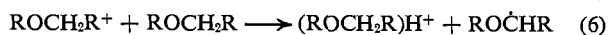
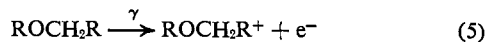

Figure 1. Absorption spectra of butadiene solution in MTHF ($\sim 0.5 M$), dose = 8×10^{19} ev/ml: (1) before photobleaching, (2) after 2-min photobleaching with a tungsten lamp.



where S is solute. On the other hand, ethers provide suitable matrices for solute anions because the positive charge is stabilized by the proton or H-atom transfer reaction (6).



Alcohols behave similarly but some solute anions react further with alcohol according to reaction 8.

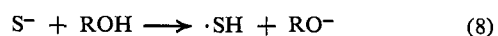

It will be shown that butadiene and its homologs yield cations, anions, and radicals, respectively, in these three matrices. Electronic absorption bands of butadiene cation and anion agree with the calculated values of λ_{max} based on simple Hückel theory.

Experimental Section

Matheson CP grade butadiene was used as received. Other dienes from K & K Laboratories were purified by passing through an alumina column and distilling under vacuum. *cis*-1,2-Pentadiene was separated from the concomitant *trans* isomer and cyclopentene by a preparative gas chromatography column (20-ft β, β' -oxydipropionitrile). Solvents were *sec*-butyl chloride (*sec*-BuCl), methyltetrahydrofuran (MTHF), and methanol. Purifications and procedures for γ irradiation, optical absorption, and epr measurements were outlined in previous papers.⁷

Results

γ -Irradiation of pure MTHF glass at -196° produces solvent-trapped electrons having a broad absorption band in the near-infrared region.⁸ Addition of butadiene to MTHF eliminated the electron band and yielded the spectrum shown in Figure 1. Very similar spectra were obtained for alkylated butadienes. The results are summarized in Table I.

Bands at both ~ 390 and ~ 570 m μ were easily photobleached proportionately for all systems, and in the presence of a second electron-scavenging solute, such

(8) P. J. Dyne and O. A. Miller, *Can. J. Chem.*, **43**, 2696 (1965).

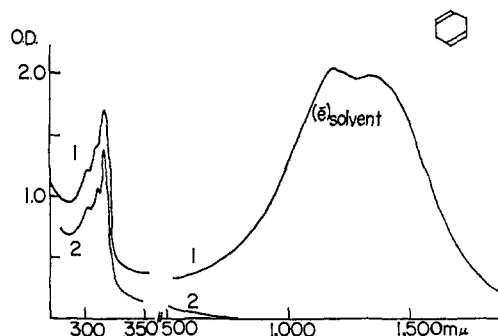
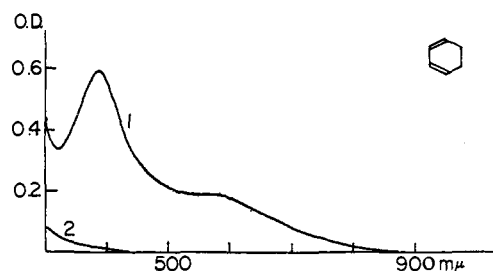

Figure 2. Absorption spectra of 1,3- and 1,4-cyclohexadiene solutions in MTHF (1,3-diene, $0.2 M$; 1,4-diene, $\sim 0.7 M$), dose = 4×10^{19} ev/ml: (1) before photobleaching, (2) after 2-min photobleaching with a tungsten lamp.

as an alkyl chloride, they were suppressed completely. The two bands are characteristic of conjugated dienes. Nonconjugated dienes, such as 1,4-cyclohexadiene and 1,5-hexadiene, did not give these bands and the solvent-trapped electron absorption did not decrease significantly. Results for 1,3- and 1,4-cyclohexadienes in MTHF are compared in Figure 2. The spectrum of the 1,3-diene solution is similar to that of butadiene. The 1,4-diene glassy solution yields the solvent-trapped electron band at 500–2000 m μ ⁸ and a band in the near-ultraviolet region which is attributable to cyclohexadienyl radical.^{7e} The yield of the radical depended linearly on the concentration of the 1,4-diene (Figure 3). In the presence of a small amount of electron scavenger (isopropyl chloride), the yield roughly doubled as the crosses in Figure 3 show. The yield was not affected by the sufficient presence of isobutene (~ 10 vol. %) which is an efficient H-atom scavenger.^{7e}

Table I. λ_{max} (m μ) of Absorption Bands in MTHF

1,3-Butadiene ^a	388	570
Isoprene	390	565
<i>cis</i> -1,3-Pentadiene	388	563
2,4-Hexadiene	390	575
2,3-Dimethyl-1,3-butadiene	390	530
1,3-Cyclohexadiene	395	~ 575
1,3-Cyclooctadiene	380	~ 500

^a Probably 98% *trans*.

Methanol glass containing 5 vol. % water produced a solvent-trapped electron band upon γ irradiation at λ_{max} 520 m μ ,^{7e} shown in curve 1 of Figure 4. Butadiene as well as its homologs diminished or suppressed the band and produced a strong new band in the ultraviolet region (curve 2). Owing to background absorption of butadiene, detailed measurement of the strong

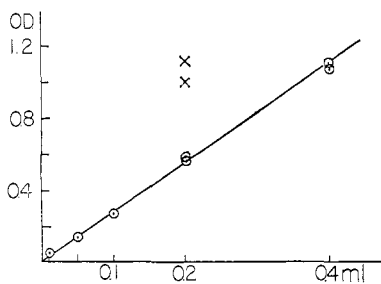

Figure 3. Optical density at 316 $m\mu$ of cyclohexadienyl radical plotted against the concentration of 1,4-cyclohexadiene. The abscissa is the milliliters of solute in 5 ml of MTHF solution, dose = 4×10^{19} ev/ml. Crosses indicate the optical densities of sample containing 0.1 M isopropyl chloride.

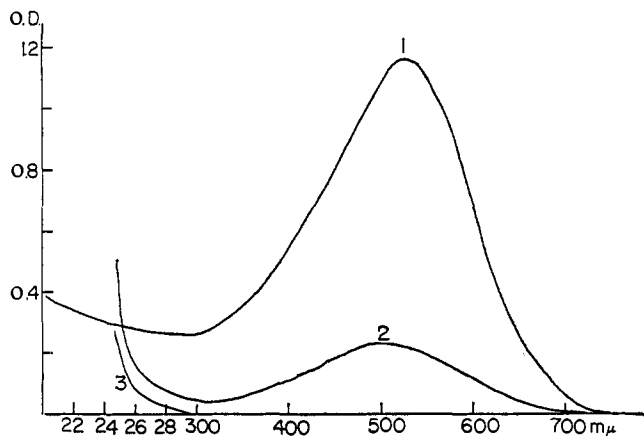
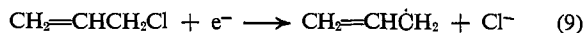

Figure 4. Absorption spectra of methanol solutions: (1) pure methanol glass (containing 5 vol. % water), (2) butadiene solution ($\sim 0.5 M$), (3) allyl chloride solution (0.1 M). Dose = 2×10^{19} ev/ml.

band was not feasible but the absorption maximum seems to be $< 250 m\mu$.

A similar band was also obtained for the allyl chloride solution in methanol glass (curve 3). Complete absence of the trapped electron band suggests that electrons have been scavenged by the chloride according to the efficient reaction⁹



The triplet epr spectrum of irradiated pure methanol glass is assigned to the methanol radical, $\dot{\text{C}}\text{H}_2\text{OH}$ (Figure 5, left).^{7e} The triplet was replaced with a quintet in the allyl chloride glassy solution where allyl radical is expected to be formed by the above reaction (Figure 5, right). The quintet spectrum did not change by photobleaching, unlike the triplet of pure methanol.^{7e} When butadiene was added to methanol a quintet spectrum, very similar to that for the allyl chloride glassy solution, appeared which also did not photobleach (Figure 6, left). Other conjugated dienes gave similar spectra, although that of 2,4-hexadiene is not well resolved (Figures 6 and 7).

The dienes in BuCl glass yielded the absorption spectra of Figures 8 and 9. The general features of the spectra in the visible region resemble those of the corresponding spectra in MTHF glass, although the small band at about 570 $m\mu$ in MTHF does not neces-

(9) D. W. Skelly, R. G. Hayes, and W. H. Hamill, *J. Chem. Phys.*, 43, 2696 (1965).

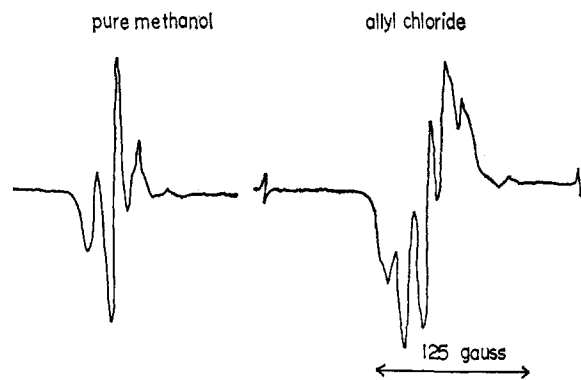

Figure 5. Epr spectra of pure methanol (left) and allyl chloride solution (0.1 M) in methanol (right). Dose = 10^{19} ev/ml.

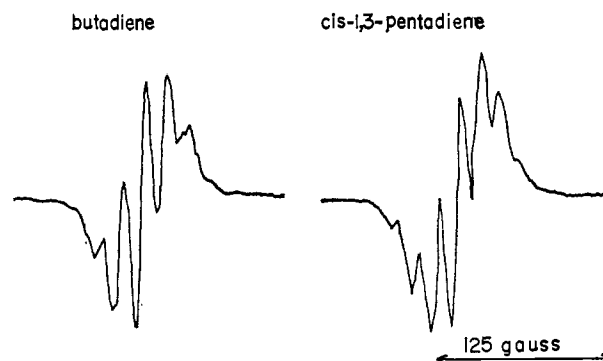

Figure 6. Epr spectra of butadiene ($\sim 0.5 M$) and *cis*-1,3-pentadiene (0.2 M) in methanol. Dose = 10^{19} ev/ml.

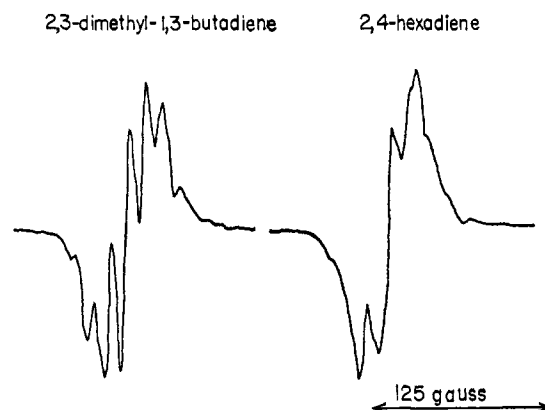

Figure 7. Epr spectra of 2,3-dimethyl-1,3-butadiene (0.2 M) and 2,4-hexadiene (0.2 M) in methanol. Dose = 10^{19} ev/ml.

sarily have a counterpart in the BuCl matrix in which the absorption bands decrease with photobleaching, but inefficiently compared to those in MTHF. The broad band at about 1200 $m\mu$ in BuCl was not found in MTHF. Photobleaching decreased proportionately the infrared and visible bands.

Discussion

Butadiene Negative Ions. The 388- and 570- $m\mu$ bands from butadiene in MTHF shown in Figure 1 are attributed to the molecular anion because butadiene suppresses the solvent-trapped electron band and because addition of efficient electron scavengers suppresses both butadiene bands. 1,3-Butadiene is one of

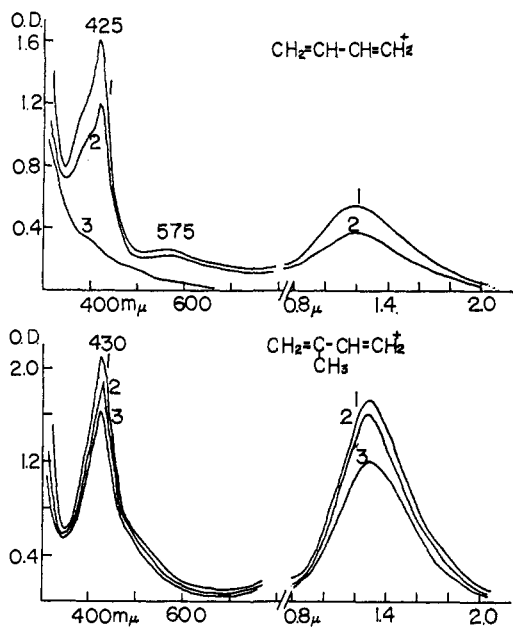

Figure 8. Absorption spectra of butadiene ($\sim 0.5 M$) and isoprene ($0.5 M$) in *sec*-BuCl. Dose = 1.5×10^{20} ev/ml.

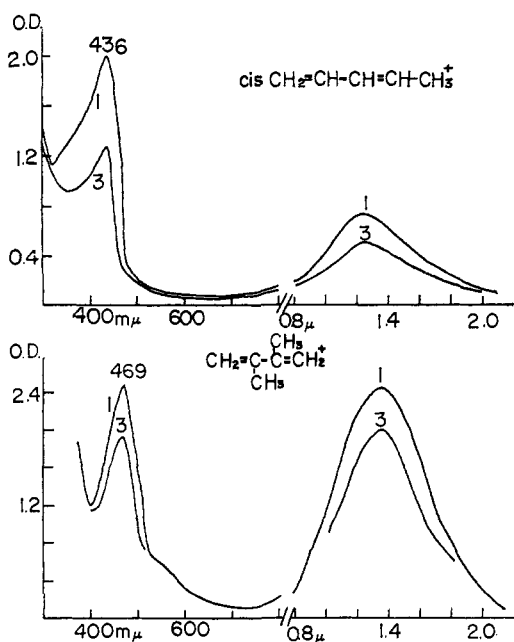

Figure 9. Absorption spectra of *cis*-1,3-pentadiene ($0.5 M$) and 2,3-dimethyl-1,3-butadiene ($0.5 M$) in *sec*-BuCl. Dose = 1.5×10^{20} ev/ml.

the simplest alternant conjugated hydrocarbons for which quantum theoretical treatments can be reasonably well applied. However, mainly due to the electron correlation problem, even for butadiene itself, satisfactory agreement between experiment and calculation is obtained only after an elaborate computation.¹⁰ Nevertheless, for mononegative ions, especially of hydrocarbons, the one-electron LCAO MO treatment is more reliable than other elaborate approximations.¹¹

(10) R. G. Parr and R. S. Mulliken, "Quantum Theory of Molecular Electronic Structure," R. G. Parr, Ed., W. A. Benjamin, Inc., New York, N. Y., 1963, p 227.

(11) P. Balk, S. de Bruijn, and G. J. Hoijsink, *Rec. Trav. Chim.*, **76**, 860 (1957).

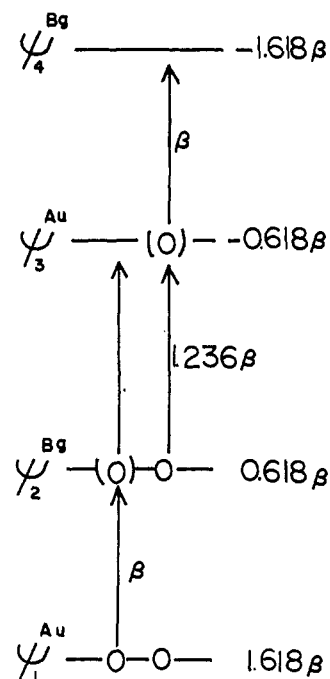

Figure 10. Energy diagram for butadiene cation and anion.

Simple MO theory is also successful in epr studies of radical ions of various compounds.¹²

Levy and Myers observed the epr spectrum of 1,3-butadiene anion and determined the ratio of the two coupling constants of protons attached to the terminal and internal carbon atoms.¹³ The ratio, which gives the relative π -electron densities on the two carbon atoms, was compared with the calculated electron density ratio based on several approximations. Again, simple Hückel molecular orbital theory (HMO) gave the best fit.

Figure 10 shows the HMO levels of butadiene as well as the lowest two transitions of molecular cation and anion.¹⁴ Therefore, if we adopt $\beta = -2.62$ ev, which is a commonly accepted value for shorter polyenes, the λ_{\max} of the two absorption bands should be about 473 and 382 $m\mu$. We assign the bands of both ions at about 400 and 570 $m\mu$ to the transitions, $\psi_2^{Bg} \rightarrow \psi_3^{Au}$ and $\psi_3^{Au} \rightarrow \psi_4^{Bg}$, respectively. The λ_{\max} of the transitions of anions in Table I are comparatively insensitive toward alkyl groups adjacent to the diene bonds, suggesting that the hyperconjugation or induction effect of CH_3 is insignificant in the anions. We will discuss later the importance of the effect in the positive ions.

While 1,3-dienes effectively capture electrons, nonconjugated dienes such as 1,5-hexadiene and 1,4-cyclohexadiene do not diminish the trapped electron band nor produce any solute anion band (Figure 2). A feature peculiar to 1,4-cyclohexadiene, however, is the production of a new band in the near-ultraviolet (Figure 2). This band did not appear in other nonconjugated, noncyclic dienes, such as 1,5-hexadiene and 2,5-dimethyl-1,5-hexadiene. Since the band is almost identical with the cyclohexa-

(12) A. Carrington, *Quart. Rev. (London)*, **67** (1963).

(13) D. H. Levy and R. J. Myers, *J. Chem. Phys.*, **41**, 1062 (1962); **44**, 4177 (1966).

(14) A. Streitwieser, Jr., "Molecular Orbital Theory for Organic Chemists," John Wiley and Sons, Inc., New York, N. Y., 1962, p 208.

dienyl radical which was observed in the benzene-methanol system^{7e} and is comparatively insensitive toward light, we assign it to the cyclohexadienyl radical. A parallel epr experiment showed clearly the formation of cyclohexadienyl radical which has a characteristic fine structure.^{7e} The mechanism of the radical formation will be discussed below.

Since the trapped electron band (Figure 2) is not affected by 1,4-cyclohexadiene, the electron cannot be a precursor of the radical. The reaction

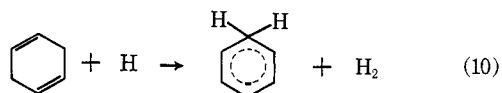

is easily ruled out because the radical yield is linearly dependent upon the solute concentration up to as high as 7.4 vol. % (Figure 3). Also, the sufficient addition of isobutene (an efficient H-atom scavenger)^{7e} to 1,4-cyclohexadiene did not decrease the yield of radical. The linear concentration dependence indicates a direct effect of radiation on the solute molecule. Such a mechanism as (11), however, is ruled out because the radical yield was almost doubled by addition of a small amount of isopropyl chloride which scavenges electrons (Figure 3).

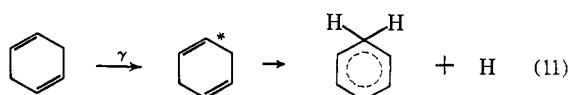

The chloride effect suggests that the radical has a cationic precursor which is either a directly ionized solute cation or an adjacent solvent cation because the radical yield depends linearly on solute concentration and positive charge migration in MTHF is very inefficient because of reaction 6. Ionized solvent molecules may induce the reactions

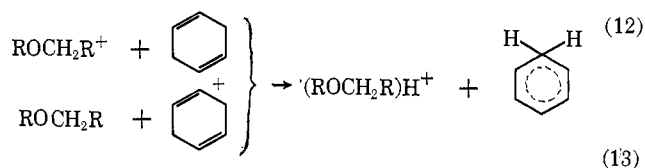

Reaction 13 implies positive charge transfer from the solvent cation to the solute followed by the proton transfer. However, these are eliminated because addition of as much as 10% (vol.) of isobutene to the solution did not depress the yield of cyclohexadienyl radical. Isobutene should behave similarly to cyclohexadiene in respect to reactions 12 and 13, thereby producing possibly an allylic radical and reducing competitively the yield of cyclohexadienyl radical. Therefore, we regard that the radical is formed from directly ionized solute cations by the reaction

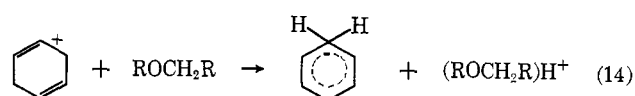

Allyl Radical. When the solvent was changed from nonprotic MTHF to alcohol, the butadiene anion band as well as the solvent-trapped electron band disappeared (Figure 4). Similar effects were observed for aromatic hydrocarbons^{7e} and carbonyl compounds^{7d} and were

explained in terms of a reaction between solute anion and alcohol (reaction 8). The same explanation seems valid for the butadiene system where reaction 8 yields an allylic radical.

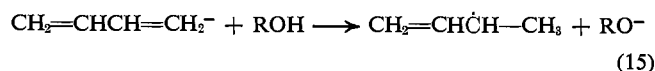

Recently Bodily and Dole reported a band at 258 $m\mu$ in irradiated polyethylene film at -196° which they assigned to an allylic radical.¹⁵ They disagreed with the previous assignment by Ohnishi, *et al.*, who also studied irradiated polyethylene and attributed a band at 236 $m\mu$ to an allyl-type radical.¹⁶ Figure 4 reveals no absorption band at about 258 $m\mu$, but there is an indication of a strong band whose λ_{max} is somewhere below 250 $m\mu$. A similar spectrum was also obtained for the allyl chloride solution in methanol (curve 3, Figure 4) where reaction 9 will produce the simplest allyl radical. Unfortunately the precise measurement of the band was not practical owing to the strong background absorption. However, the inadequacy of the optical data is well enough compensated by the epr evidence for the formation of allyl radical. The quintet epr spectrum of butadiene in methanol (Figure 6) agrees with the reported spectrum for allyl radical,¹⁷ and with the spectrum obtained for the allyl chloride solution in methanol (Figure 5, right). As Ayscough and Evans¹⁷ noted, hyperfine splitting of the allyl radical is not changed by the substituent alkyl group. This is seen in Figures 6 and 7 where the spectra for isoprene, 1,3-pentadiene, and 2,4-hexadiene are essentially identical with that for butadiene.

Butadiene Positive Ions. On the basis of earlier work we expect to form butadiene cation in the BuCl matrix by the mechanism of reactions 1-5, because the respective ionization potentials are 9.07 and 10.65 ev. Therefore the spectra in Figures 8 and 9 are assigned to positive ions of the butadienes.

In the HMO treatment of alternant hydrocarbons, the energy levels of bonding and antibonding orbitals are mirror images. As a consequence of this pairing, electronic spectra of positive and negative ions should be similar and the bands at 425 and 575 $m\mu$ of Figure 8 are correlated to those at 390 and 575 $m\mu$ of Figure 1. To account for the red shift of the 425- $m\mu$ band relative to the 390- $m\mu$ band of anion, we have used the so-called ω technique of Streitwieser and Nair which distributes positive charge more evenly throughout the cation.¹⁸ The result, however, locates the shorter band of the cation at about 380 $m\mu$. Possibly involvement of σ electrons is necessary to predict correctly the shift in the positive ion.

The band shift of methylated butadiene cations suggests hyperconjugation or inductive effects due to the methyl group. Based on the heteroatom model for the methyl group,¹⁸ we calculated the transition $\psi_2 \rightarrow \psi_3$ of the ions which, however, turned out to change little from that of the prototype butadiene. In view of somewhat arbitrary choices of molecular constants and

(15) D. M. Bodily and M. Dole, *J. Chem. Phys.*, **44**, 2821 (1966).

(16) S. Ohnishi, S. Sugimoto, and I. Nitta, *ibid.*, **39**, 2647 (1963).

(17) P. B. Ayscough and H. E. Evans, *Trans. Faraday Soc.*, **60**, 801 (1964).

(18) A. Streitwieser, Jr., and P. M. Nair, *Tetrahedron*, **5**, 149 (1959).

the limited applicability of the result, no attempt was made to explain the band shift in terms of other simple models.

The similarity of cation and anion spectra fails in the near-infrared region where a broad band at about 1200 $m\mu$ appeared for cations of all four butadienes,

but not for anions. Since photobleaching decreases the infrared band and the visible bands proportionately, all arise from a common ionic species. A similar band was observed for olefin cations and attributed to a σ - π transition. The same assignment is applicable to cations of butadiene homologs.

Molecular Ions. VII. Positive Ions of Olefins in γ -Irradiated Organic Glasses

Tadamasa Shida¹ and William H. Hamill

Contribution from the Department of Chemistry and the Radiation Laboratory,² University of Notre Dame, Notre Dame, Indiana 46556. Received August 3, 1966

Abstract. Vinylene- and vinylidene-type olefins appear to form their molecular cations in γ -irradiated alkyl chloride or alkane glass. Cations of vinyl-type olefins apparently react completely with solvent molecules. Molecular cations of the first two types of olefin have a broad absorption band at about 600–800 $m\mu$ which has been assigned to a transition of a σ electron to the half-occupied π orbital of the ions. λ_{\max} of the cation band shifts noticeably depending on the number and position of alkyl groups adjacent to the ethylenic bond. In pure γ -irradiated olefin glasses, positive charge migrates to solute molecules efficiently.

Positive charge migration has been observed in several γ -irradiated organic matrices at -196° , including aliphatic halides and alkanes.³ The evidence for this effect is the formation of appreciable yields of authentic molecular positive ions of additives at small concentrations (e.g., Wurster's Blue from tetramethyl-*p*-phenylenediamine.^{3a}) In an alkane matrix such yields are strongly enhanced by addition of a small amount of alkyl halides or other electron scavengers because ejected electrons are efficiently scavenged by the reaction



thereby inhibiting charge recombination and increasing the yield of stabilized positive ions. Because of the above reaction and comparatively high ionization potentials, alkyl chlorides are especially suitable as matrices for positive charge transfer to additives. A considerable number of molecular positive ions have been prepared in such matrices, particularly aromatic amines,^{3a} aromatic hydrocarbons,^{3b,c} both aliphatic and aromatic ketones,^{3d} and conjugated dienes.^{3f}

Olefins, because of their relatively low ionization potentials, would be expected to trap positive charge in γ -irradiated alkyl chloride matrices. All olefins of vinylene- ($-\text{CH}=\text{CH}-$) and vinylidene-type ($\text{CH}_2=\text{C}<$) which were tested produced a broad absorption band at about 600–800 $m\mu$ in such matrices while vinyl-type ($\text{CH}_2=\text{CH}-$) olefins did not. To test whether the band is due to a cationic color center or not, several procedures have been developed.³ Addition of aromatic amines such as dimethylaniline should depress

the yield of cationic color centers. Polar substances such as alcohol should also decrease the yield because they are known to scavenge positive charge by proton transfer. The tests indicated that the band at 600–800 $m\mu$ for vinylene and vinylidene olefins is associated with a cationic species. The same band appeared also when such olefins were added to the 3-methylpentane matrix and were attributed to some cations of the olefins.⁴ Because the bands appear in the red and near-infrared spectral region for many olefins, they will be designated as R-band. It will be shown in this work that the R-band is attributable to the molecular cation of olefin. For vinyl-type olefins, the molecular cation apparently reacts further with a neutral molecule to produce a carbonium ion.

Experimental Section

Olefins were obtained from Aldrich Chemical Co. and K & K Laboratories. They were purified by passing through an alumina column, distilling under vacuum, and in some cases by storing over a sodium mirror under vacuum for several days. The solvents, *n*- and *sec*-butyl chloride (BuCl), CCl_4 , CCl_3Br , and 3-methylpentane (3MP) were purified on a silica gel column followed by distillation. The olefin solution was introduced to a 0.16-cm thick Suprasil optical cell in air, unless otherwise stated, and the cell was plunged into liquid nitrogen. Procedures of irradiation and optical measurements have been described.^{3a} All results described here refer to samples which were γ -irradiated and examined at -196° . All matrices were glassy solids except CCl_4 and CCl_3Br which were polycrystalline.

Results

γ -Irradiated pure BuCl (*n*- and *sec*-) glasses produce an absorption band at about 400–600 $m\mu$ which has been attributed to the solvent-trapped positive hole (BuCl^+).^{3c} Addition of olefins caused the (BuCl^+) band to decrease or disappear, and a new band, designated as R-band, appeared at about 600–800 $m\mu$ for

(1) On leave from the Institute of Physical and Chemical Research, Tokyo, Japan.

(2) The Radiation Laboratory of the University of Notre Dame is operated under contract with the U. S. Atomic Energy Commission. This is A.E.C. Document No. COO-38-504.

(3) (a) T. Shida and W. H. Hamill, *J. Chem. Phys.*, **44**, 2369 (1966); (b) *ibid.*, **44**, 2375 (1966); (c) *ibid.*, **44**, 4372 (1966); (d) *J. Am. Chem. Soc.*, **88**, 3683 (1966); (e) *ibid.*, **88**, 3689 (1966); (f) *ibid.*, **88**, 5371 (1966).

(4) J. P. Guarino and W. H. Hamill, *ibid.*, **86**, 777 (1964).